

CONSTRUCTION DETAIL			CONSTRUCTION DETAIL (CONTINUED)		
Element	Cd	Description	Element	Cd	Description
Style:	01	Ranch			
Model	01	Residential			
Grade:	03	Average			
Stories:	1	1 Story			
Occupancy	1				
Exterior Wall 1	25	Vinyl Siding			
Exterior Wall 2					
Roof Structure:	03	Gable/Hip			
Roof Cover	03	Asph/F Gls/Cmp			
Interior Wall 1	03	Plastered			
Interior Wall 2					
Interior Flr 1	14	Carpet			
Interior Flr 2	12	Hardwood			
Heat Fuel	02	Oil			
Heat Type:	04	Forced Air-Duc			
AC Type:	03	Central			
Total Bedrooms	03	3 Bedrooms			
Total Bthrms:	2				
Total Half Baths	0				
Total Xtra Fixtrs					
Total Rooms:	6	6 Rooms			
Bath Style:	02	Average			
Kitchen Style:	02	Average			
Fireplace	1				
Fireplace openi					
Gas Fireplace					
			Use Code		
			Code	Description	Percentage
			1010	SINGLE FAM MDL0	100
COST / MARKET VALUATION					
			Year Built	1947	
			Eff Age %	20	
			Living Area	1243	
			Replacement Cost	199,802	
			Depreciation Code	G	
			Replacement Cost Less Depr	159,800	
			Condition		
			Condition %		
			Functional Obslnc	0	
			External Obslnc	0	

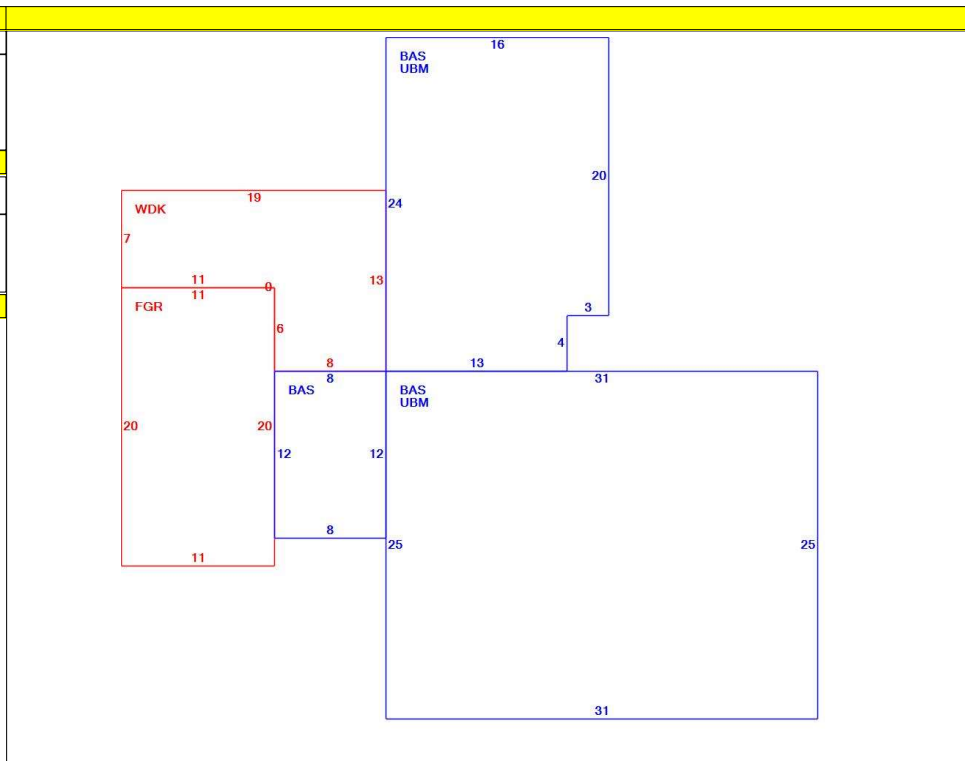

OB - OUTBUILDING & YARD ITEMS(L) / XF - BUILDING EXTRA FEATURES(B)												
Code	Descript	Sub	Sub Ty	L/B	Units	Unit Pric	Yr Blt	Cond. C	% Gd	Grade	Grade A	Appr. V

BUILDING SUB-AREA SUMMARY SECTION							
Code	Description	Living Area	Gross Area	Eff Area	Unit Cost	Undeprec Value	
BAS	First Floor	1,243	1,243	1,243	122.72	152,541	
FGR	Garage	0	220	77	42.95	9,449	
UBM	Basement, Unfinished	0	1,147	229	24.50	28,103	
WDK	Deck, Wood	0	181	18	12.20	2,209	
Ttl Gross Liv / Lease Area		1,243	2,791	1,567		192,302	

